



# BIKE-PACK SYSTEM™

Thank you for purchasing our VENTURA BIKE-PACK SYSTEM.  
Before use please read all instructions and our Limited Warranty carefully.

**To Fit : Buell Firebolt XB9R (03-04),  
Firebolt XB12R (03-09)**

**BU008/B** L-Brackets  
**PF12/B** Pack-Rack  
**SR12/B** Sport-Rack  
**GH12/18/B** Grab-Handle

A range of various style packs for the Aerodynamic systems, along with storm covers and optional straps (where applicable) are available.

Check with your local dealer, distributor or contact us direct for the latest models.

## FITTING KIT CONTENTS

LD001/B locking device (fitted to L-Brackets)

- 1 LK001/S Key
- 1 BU008 Crossmember
- 2  $\frac{3}{8}$ " x  $1\frac{3}{4}$ " UNC Allenhead bolts (zp)
- 2 M8 x 35 Allenhead bolts (black zp)
- 2 M8 x 40 bolts (black zp)
- 2 M8 x 80 Allenhead bolts (black zp)
- 2 Part #460 – special nut (black zp)
- 2 M8 Spring washers (black zp)
- 10 M8 x 17.0 x 1.4 flat washers (black zp)
- 2 Part #462 Mounting brackets (black zp)
- 2 M8 Nyloc nuts (black zp)

## FITTING INSTRUCTIONS

- 1 Remove the pillion and riders seats, and rear body.
- 2 Remove and discard the pillion footrest casting to subframe, rear mounting bolts. At this mounting bolt the part #462 brackets, using the  $\frac{3}{8}$ " x  $1\frac{3}{4}$ " Allenhead bolts provided. Leave loose.

## Diagram #1

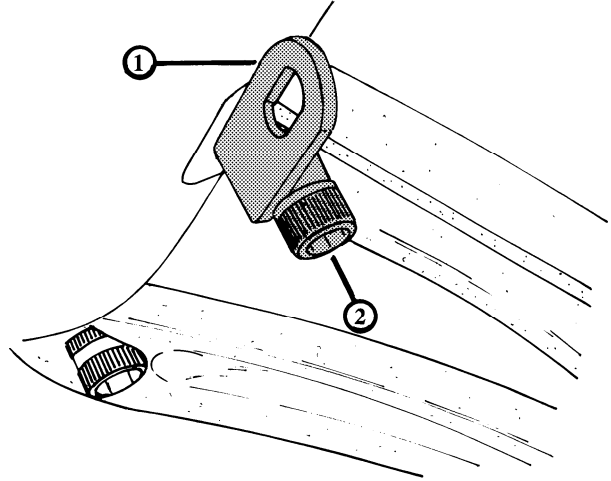

## Legend to Diagram #1

- (1) Part #462 mounting bracket
  - (2)  $\frac{3}{8}$ " x  $1\frac{3}{4}$ " Allenhead bolts
- 3 Disconnect and remove the turn signal indicators.
  - 4 Remove the inner mudguard mounting bolts, allowing the inner guard to hang downwards.
  - 5 Cut the templates from the instructions. Place over the holes where the turn signal indicators have been removed. Mark the centre of the new hole and drill an M6 ( $\frac{1}{4}$ " ). This will be for rerouting the indicator wires.
  - 6 Fit the BU008 crossmember upwards, underneath the rear frame. Place the two special nuts down through the large top holes and secure the crossmember vertically from underneath with the M8 x 40 bolts, M8 spring and flat washers supplied. Leave loose.

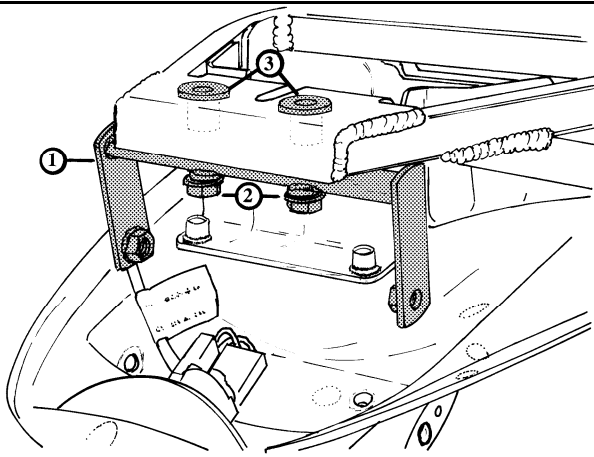

Diagram 2

Legend to Diagram 2

- ① BU008 Crossmember
- ② M8 x 40 bolts with M8 spring and flat washers
- ③ Special nut

- 7 Raise the inner mudguard to its original position. Refit the number plate mounting bracket and inner mudguard mounting bolts.
- 8 The L-Brackets bolt to the part #462 mounting bracket in the front, using the M8 x 35 Allenhead bolts, with M8 flat washers and nyloc nuts on the inside. Leave loose. The mounting bolts through the hole left by the removal of the indicators, using the M8 x 80 Allenhead bolts provided, insert an M8 flat washer between the tubular rear mounting and the reflector mounting bracket. Leave loose.

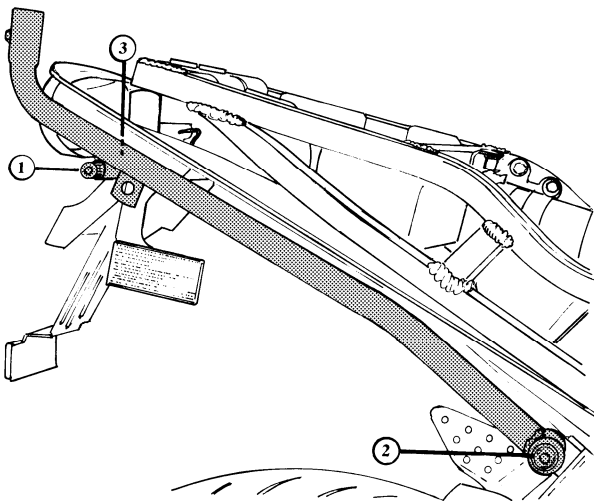

Diagram 3

Legend to Diagram 3

- ① M8 x 80 Allenhead bolt
- ② M8 x 35 Allenhead bolt with M8 flat washer and M8 nyloc nut
- ③ M8 flat washer

- 9 Refit the turn signal indicators in the new mounting provided on the L-Brackets and route the wires through the new holes and reconnect the wiring plugs.
- 10 Fit Pack-Rack or Sport-Rack into the L-Brackets, ensure the rack is level and tighten all the mounting bolts. Remove the rack (extra M8 flat washers are provided and can be used to adjust the width at the rear mounting if required).
- 11 Refit the rear body and seats.
- 12 Refit the rack and tighten the L-Bracket locking devices by following the procedure in the General Instructions for Use.

GENERAL INSTRUCTIONS FOR USE



The following instructions should be strictly adhered to. Failure to do so may result in an accident causing injury or death.

Locking Device Tightening Instruction

For racks with formed indents on swaged ends.

- 1 Ensure the knurled locking nut is wound fully back and is in contact with the head of the locking device.
- 2 Tighten the locking device firmly and securely by hand making sure that it is centrally located in the indented groove on the swaged legs of the rack.
- 3 Turning the knurled locknut clockwise, tighten firmly by hand. Using the key tighten an extra 2mm (1/8" approx) of circumference travel.

For racks without indents

- 1 Ensure the knurled locking nut is wound fully back and is in contact with the head of the locking device.
- 2 Tighten the locking device by hand until it comes into positive and firm contact with the rack.
- 3 Using the key, tighten a further 1.125 (1 1/8) turns.
- 4 Turning the knurled locknut clockwise, tighten firmly by hand. Using the key tighten an extra 2mm (1/8" approx) of circumference travel.

BEFORE USE

All fasteners and components must be checked for tightness and security before each ride.

RECOMMENDATION

Any surfaces that could possibly come in contact with the pack(s) should be covered with protective material such as abrasion resistant film, to prevent marking or damage to the surface finish.

RIDING SOLO

When riding solo always have the pack facing forward with the load over the pillion seat.

RIDING WITH A PILLION PASSENGER

When riding with a pillion passenger the pack must be fitted facing rearwards.

WARNING -

The VENTURA Bike-Pack System was not designed as a back rest and should not be used as one by the pillion passenger.

#### SECURING PACK TO PACK-RACK

To secure the pack use the straps with the quick release clips and attach around the horizontal rung on the Pack-Rack carrier. On some models the quick release system is not available. In this situation loop the shoulder straps around the rung and fasten to the buckle. If the securing straps hang down below the rack, loop the excess up behind the quick release clips.

#### PACKING THE PACK

Always place heavy items at the bottom of the pack and load evenly. Do not position sharp objects against the fabric of the pack.

#### MAXIMUM CARRYING CAPACITY

Unless specified to the contrary in the fitting instructions or the motorcycle manufacturers recommendations/specifications the recommended maximum load capacity of this system is 9kg (20lbs). It is important that the pack is always securely fastened to the Pack-Rack.

#### MAXIMUM SPEED

The maximum recommended speed that this system can be used is 130 kph (80mph) or the legal speed limit, whichever is the lower. This limit may be reduced by other accessories, worn tyres, improper handling, overall motorcycle condition or weather conditions.

#### REMEMBER

Exceeding the weight capacity or the recommended maximum speed may drastically affect the motorcycles handling, stability and performance.

#### L-BRACKETS

The L-Brackets must always have the Pack-Rack, Sport-Rack or Grab-Handle fitted.

#### ADDITIONAL REAR VISIBILITY

We now have available an auxiliary LED stop/tail lamp. It is flexible and can be mounted on flat or curved surfaces.

#### IMPORTANT

The **VENTURA BIKE-PACK SYSTEM** is designed as a complete unit. The use of non **VENTURA** parts, bags or other attachments will render the warranty void.

The following **VENTURA** accessories are available for these/this model motorcycle(s):

**VENTURA** Auxiliary LED Lamp : VTL-001

**"Happy and Safe Motorcycling"**

#### LIMITED WARRANTY

**NOTE: Some jurisdictions do not allow limitations on how long an implied warranty, if any, lasts, and do not allow the exclusion of limitation of incidental or consequential damages so the limitations and exclusions below may not apply to you. This warranty gives specific legal rights, you may have other rights which vary from jurisdiction to jurisdiction.**

Dold Industries Limited ("Dold") warrants this product to be free from defects in materials and workmanship under normal use and maintenance for a period of one year from its date of original purchase. Dold shall, at its option, either repair or replace a defective product returned to it or its authorised agents, freight prepaid.

**This warranty does not apply to any product which has been altered, damaged or rendered non-functional through improper installation or maintenance, abnormal wear and tear due to exposure to the elements, negligence, abuse, accidents or any like circumstance.**

**Dold shall not be liable for any incidental nor consequential loss or damage resulting directly or indirectly from any defective product, its sole obligation being to repair or replace such defective product.**

This warranty is in lieu of, and excludes, all other warranties, expressed or implied, including the warranties of merchantability and of fitness for a particular purpose.

To make a warranty claim return the product to the dealer who supplied it with evidence of date of purchase. If you are not satisfied with their response, please contact the distributors for your country or: Dold Industries Ltd, 128-134 Maui Street, P O Box 10-393, Hamilton, New Zealand.

Telephone +64 (7) 849-4392. Facsimile +64 (7) 849-4114.

E-mail: [dold@ventura-bike.com](mailto:dold@ventura-bike.com) Internet: [www.ventura-bike.com](http://www.ventura-bike.com)

E & O E

